

TOPIV Series

80~350 Ton

Power : 100Vac~240Vac, 0.6A, 50/60Hz
 Take-out Dry Cycle : 0.7sec(TOPIV-A550)
 Control : Sequence Program
 Total Dry Cycle : 3.2sec(TOPIV-A550)
 Air Pressure : 0.4 to 0.5Mpa(70PSI)
 Noise Level : 66dB / Max. Payload : 2kg

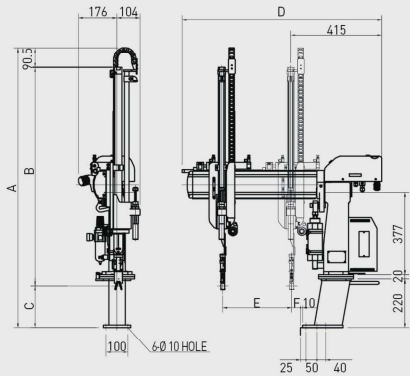

- Feature**
- CE Certified
 - ISO 9001 Quality Certified
 - Designed with a modern for a simple and new injection molding plant.
 - Minimized wire exposure for long time operation Safety and prevention of crane interference when changing molds.
 - Easy to adjust various positions.

Dimension

Unit : mm

Model	A	B	C	D	E	F
TOP IV-A, X, XC 450	1175	896	188.5	910	320	40
TOP IV-A, X, XC 550	1275	996				
TOP IV-A, X, XC 650	1375	1096				
TOP IV-A, X, XC 750	1475	1196	1110	520		
TOP IV-A, X, XC 950	1675	1340			244.5	

- A-Type** : Sprue taking out only.
- X-Type** : When the product is put on the conveyor chute, the chuck is inverted by 90 degrees to prevent the molded product from being damaged.
- XC-Type** : Take out the non-chuckable product by suction. Chuck and 4 point suction pad standard specification. The robot head rotate 90 degrees.

Technical Specification

Model	Injection Molding Machine	Descent Stroke (mm)	Crosswise (mm)	Swing Angle (Deg) (°)	Ascent Position (mm)	Air Consumption [ℓ(normal)/Cycle]	Net Weight (kg)
TOP IV-A, X, XC 450	80 Ton	450	90	50~80	100	7	34
TOP IV-A, X, XC 550	120 Ton	550				8	35
TOP IV-A, X, XC 650	180 Ton	650				9	36
TOP IV-A, X, XC 750	220 Ton	750	10			37	
TOP IV-A, X, XC 950	350 Ton	950	150			12	38

All information subject to change without notice for quality improvements.

TOPIV TWIN Series

80~350 Ton

Power : 100Vac~240Vac, 0.6A, 50/60Hz
 Take-out Dry Cycle : 0.7sec(TOPIV-A550)
 Control : Sequence Program
 Total Dry Cycle : 3.2sec(TOPIV-A550)
 Air Pressure : 0.4 to 0.5Mpa(70PSI)
 Noise Level : 66dB / Max. Payload : 2kg

- Feature**
- Possible to take out the product and runner of compact injection machine (80~350 TON) at the same time
 - Incorporates a 4-points suction head and suction confirmation circuit to safely take out the product

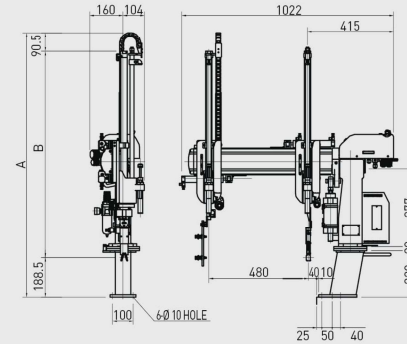

Dimension

Unit : mm

Model	A	B
TOP IV-TWIN 450	1175	896
TOP IV-TWIN 550	1275	996
TOP IV-TWIN 650	1375	1096
TOP IV-TWIN 750	1475	1196

Technical Specification

Model	Injection Molding Machine	Descent Stroke (mm)	Crosswise (mm)	Swing Angle (Deg) (°)	Ascent Position (mm)	Air Consumption [ℓ(normal)/Cycle]	Net Weight (kg)
TOP IV-TWIN 450	80 Ton	450	90	50~80	100	11	44
TOP IV-TWIN 550	120 Ton	550				13	46
TOP IV-TWIN 650	180 Ton	650				15	48
TOP IV-TWIN 750	220 Ton	750	17			49	

All information subject to change without notice for quality improvements.